

Weekend Welcome Dance- SPRING FLING, FRINGE & SCHOOL

1 KIRSTY'S CEILIDH J32 · 3+3RR

Peggy Rose: The Helensburgh Golden Jubilee Dance Book · Crib: MiniCribs · Diagram: Keith Rose's Diagrams

Round the Room 3 facing 3

- 1-8 All circle 6H round & back
- 9-16 All turn opposite person RH, all turn opposite person LH
- 17-24 Middle person dances RH across with partner & opposite person on right & LH back
- 25-32 All Adv+Ret for 2 steps & pass RH to meet next trio

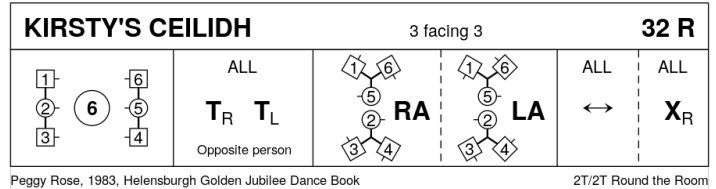

2 STARLIGHT R32 · 3/4L

Ed Abdill: RSCDS XLIV 1 · Crib: MiniCribs · Diagram: Keith Rose's Diagrams

- 1-8 1s cross RH, cast 1 place, PdB in turn right about to face opposite sides & set as double triangles
- 9-16 1s dance out, cast round 1st corners into centre **while** 2s+3s Adv+Ret diagonally, 1s PdB towards each other & turn right about to face up/down & set as double triangles
- 17-24 1s dance up/down, cast to right to 2nd place own sides **while** 2s+3s Adv+Ret, 1s dance RH across (1L with 2s & 1M +3s) end facing 1st cnrs
- 25-32 1s dance 'Hello-Goodbye' setting ending with petronella turn to 2nd places

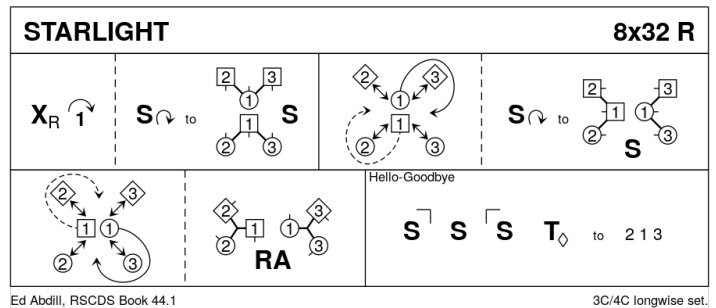

3 HIGH TIME S32 · 2/4L

Kenton Stutz: High Time · Crib: E-cribs · Diagram: Keith Rose's Diagrams

- 1-- 1M advances | 1M+1W+2W set ; ½ Circle3 L (2M up on [5-6]) | 1M crosses to 2pl **while**{2} 1W+2W change places BH (2,1)
- 9-- 1W repeat [1-9] with 1M & 2M, 2W stepping down on [13-14] (1,2)
- 17-- 1c Petronella Turn | A&R to centre {1+1} taking RH briefly ; »Rsh Turn« [Dance Rsh round P to 1pl] (1,2)
- 25-- 1c+2c Circle4 L to finish on 1diag facing P : into ½ Poussette (2,1)

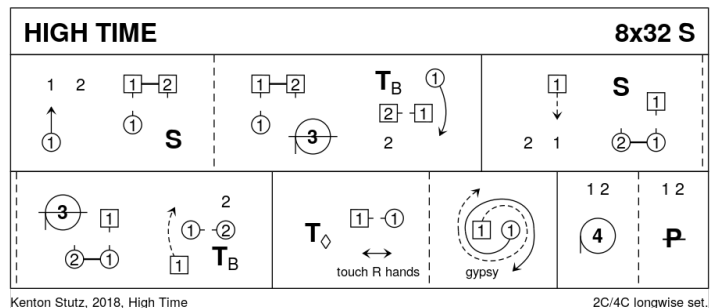

Note:

»Rsh Turn« (Right Shoulder Turn) is also known as Gypsy Turn, a term now considered offensive by some.

4 LINKS WITH ST PETERSBURG

J32 · 3/4L

Malcolm Brown: RSCDS XLVI 10 · Crib: MiniCribbs · Diagram: Keith Rose's Diagrams

- 1-8 1s & 2s Set+Link ending 2s facing 1s NHJ, 2s & 1s Set+Link with partners to opposite sides. (2)(1)3
- 9-16 1s followed by 2s dance down for 3 bars & change places with Lady dancing under Mans arm, 2s+1s dance up to 1st & 2nd places
- 17-24 2M+1M turn LH as 2L+1L turn RH, 1M+3M turn RH as 1L+3L turn LH & 1s end facing 1st corners
- 25-32 1s dance 'Hello-Goodbye' setting & petronella turn to 2nd place own sides

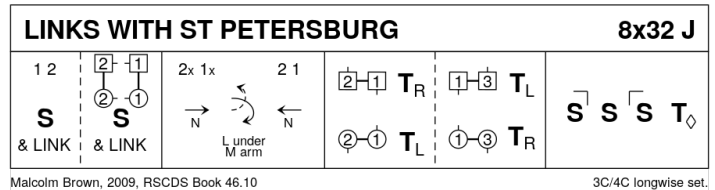

5 SHIFTIN' BOBBINS

R32 · 3/4L

Roy Clowes: Thirty Popular Dances, Volume Two · Crib: MiniCribbs · Diagram: Keith Rose's Diagrams

- 1-8 1s cross RH to double triangle position with 2s+3s & set, 1s cast up to top & dance down until they are between 2s & 3s
- 9-16 1L dances RH across with 2M+3M **while** 1M dances LH across with 2L+3L, 1s followed by 2s+3s dance down centre
- 17-24 3s followed by 2s+1s dance up & 3s+2s cast down to places, 1L dances LH across with 2M+3M **while** 1M dances RH across with 2L+3L
- 25-32 1s dance up to top & cast down to 2nd place opposite side, 1s dance 1/2 Fig of 8 around 2s to end in 2nd place on own sides

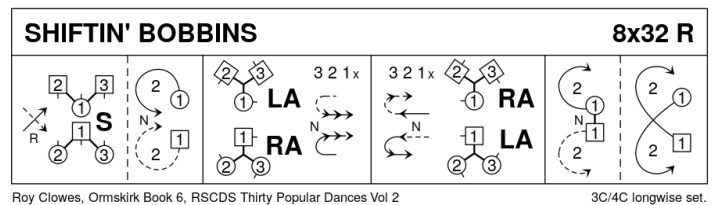

6 NEVSKIY PROSPEKT

S32 · 3/3L

Anselm Lingnau · Crib: SCDDDB Contributed Cribbs & Diagrams · Diagram: SCDDDB Contributed Cribbs & Diagrams

- 1- 1c set | cast off (2c up) ; 1c lead down crossing RH | cast up [fin 21x3 in middle, 2c&3c facing up, 1c facing down]
- 9- Circulating allemande for 3 couples [on 15-16, 1c turn ¾ RH to fin facing 2nd corner places]
- 17- Corners pass and turn on 2nd corner diagonal (corners turn BH) – at end, 1c dance round partners LS to fin facing 1st corner places ; corners pass and turn on 1st corner diagonal (corners turn BH) – 1c fin in 2nd place own sides.
- 25- Circle6 and back

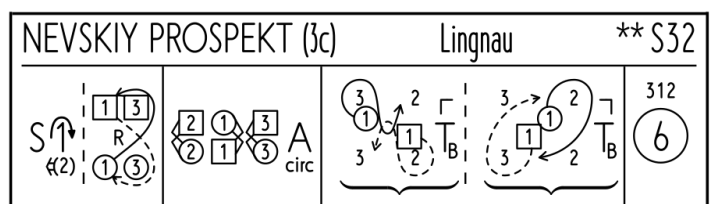

7 THE AVIATOR J32 · 3/4L

Carola Fischer: RSCDS LII 9 · Crib: MiniCribs · Diagram: Keith Rose's Diagrams

- 1-8** 1s lead down, on bar 4 1M crosses partner in front & 1L followed by 1M cast up behind 4M & 3M & across into 2nd place facing 3L (2s step up 3-4)
- 9-16** 1s (1L leading) dance 1/2 alternating tandem reel with 1st corners; 1M continues reel with corners passing 3L LSh **while** 1L+3M turn LH to face 2L
- 17-24** 1s (1M leading) dance 1/2 alternating tandem reel with 2nd corners; 1L continues reel with corners passing 2L LSh **while** 1M+3L turn LH. 1s end in 2nd place opp sides, 1L facing out
- 25-32** 1s dance up, round 2s by RSh (1L behind 2M, 1M in front 2L) & 1M followed by 1L cast 1 place, across set to end in 2nd place own side (6 bars). All 3 couples set

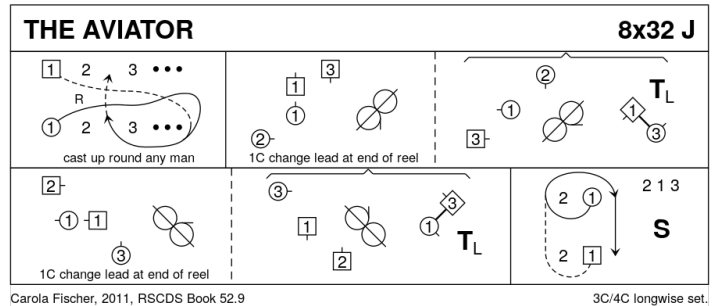

8 INTERVAL

9 THE FLIRTATION HORNPIPE R32 · 4/4L

Jane Wallace · Crib: MiniCribs · Diagram: Keith Rose's Diagrams

- 1-8** 1M+2M+3M dance across, pass partner LSh, dance RSh round Lady below & LSh round partner & across back to place (i.e. Fig 8 on opp side)
- 9-16** 1L+2L+3L repeat above Fig. passing partner RSh, LSh round Man below & RSh round partner, back to place
- 17-24** 1M+2L change places RH
1L+2M also 1M+3M change places LH
1L+3L also 1M+4L change places RH
1L+4M change places LH
- 25-32** All advance to pass partner RSh, turn to face partner & retire to own sides; all turn partners RH to end 2 3 4 1

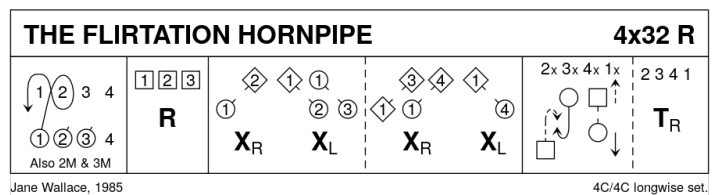

10 GROUNDHOG DAY S32 · 2/4L

Sergey Kargapoltsev: Eight by Thirty-Two · Crib: SCDDDB Contributed Cribs & Diagrams · Diagram: Anton Korobeynikov's Diagrams

- 1-8** 1s+2s Set & Cross RH, Set & 3/4 Turn Both Hands to face each other in the middle (Man facing down, ladies facing up).
- 9-16** 1s+2s dance reel of 4 in the middle
- 17-24** 1s+2s Set to each other in the middle & turn RH to the own Side, Set & 3/4 Turn Both Hands in the middle (facing up), ready for...
- 25-32** 1s+2s dance Allemande.

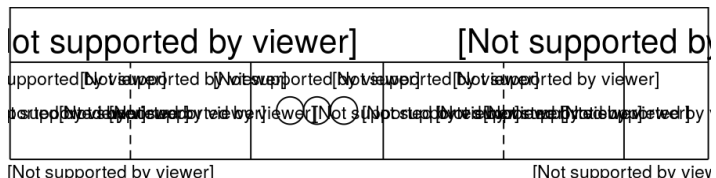

11 BIRLS ALLOWED J32 · 3/4L

Alex Taylor: Bannockburn 700 · Crib: MiniCribs · Diagram: Keith Rose's Diagrams

- 1-8** 1s cross RH & cast 2 places (3s face down), 1s with 3s+2s dance 1/2 reflection reel of 3 (1s dancing in/up, 3s down/out, 2s in/down to start) (1) 3 2
- 9-16** 1s cross down to dance full reels of 3 on own sides. 1 3 2
- 17-24** 3s+2s (bottom 2 couples) Set & Rotate: Set, rotate singly & dance on 1 place clockwise, change places RH on sides & dance on 1 place to own sides (3s in 2nd pl). 1 2 3
- 25-32** 1s+2s dance 1/2 R&L, 2s+1s turn partner 1.1/2 times RH. 2 1 3

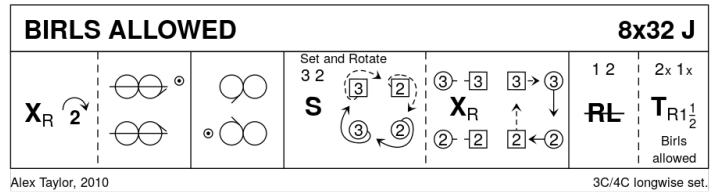

12 SPEEDY LIFE IN PARIS R32 · 3/4L

Hervé Raymond: The Paris Book of Scottish Country Dances, vol. 1 · Crib: E-cribs · Diagram: Keith Rose's Diagrams

- 1--** 1c set | cross RH ; cast (2c up) | set advancing pulling RSh back to face 1cnrs
- 9--** Set H&G. On [15] all clap (2,1,3)
- 17--** 1c turn 1cnrs RH, pass RSh ; turn 2cnrs RH to 2plx | all set (2,1x,3)
- 25--** 1c turn 1cnrs LH | turn 2cnrs RH ; cross LH to 2pl | all set (2,1,3)

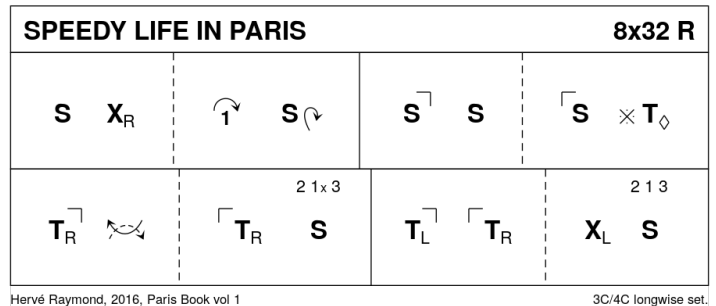

13 THE DOUBLE DIAMOND STRATHSPEY S32 · 4/4L

Roy Goldring: Social Dances 2002 (Leeds RSCDS 40th Anniversary Book) 6 · Crib: MiniCribs · Diagram: Keith Rose's Diagrams

- 1-8** 1s+2s also 3s+4s dance Diamond Poussette
- 9-16** 1L+2M also 3L+4M pass RSh turn to face each other & turn about to dance into others place, 1M+2L also 3M+4L repeat
- 17-24** 1s & 3s dance 1/2 Fig 8 round couple above them, 2s & 4s dance 1/2 Fig 8 round couple below
- 25-32** 1s+4s+3s (bottom 3 cpls) dance the Knot

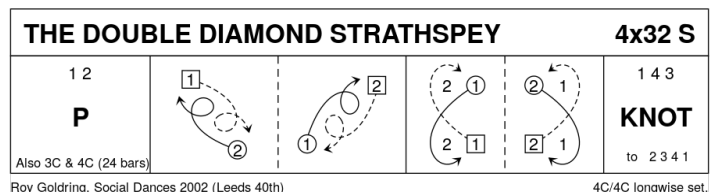

14 NEIL M GRANT J32 · 3/4L

Christine Grant: RSCDS XLIX 1 · Crib: MiniCribs · Diagram: Keith Rose's Diagrams

- 1-8** 1s cross RH, cast (2s step up). 1s dance 1/2 Figs 8 (1M round 2s, 1L round 3s) & join LH giving RH to 1st corners
- 9-16** 2s+1s+3s dance The Spoke: 1s Bal-in-Line with 1st corners, then 2nd, 3rd & 4th corners. 1s finish facing 1st corners
- 17-24** 1s dance 1/2 diagonal reel of 4 with 1st corners, pass RSh, dance 1/2 diagonal reel of 4 with 2nd corners to finish in 2nd place, opp sides facing clockwise
- 25-32** 3s+1s+2s dance clockwise 1/2 way round. 1M+3s & 1L+2s dance RH across

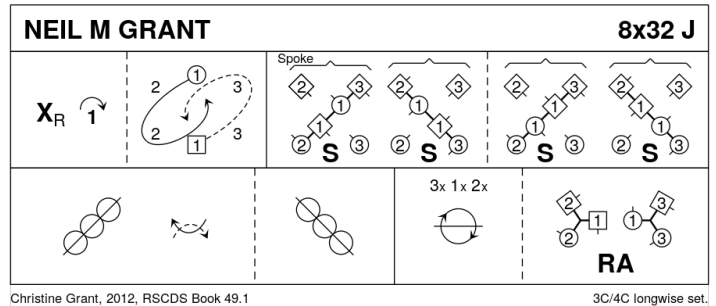

15 FESTIVAL FLING R32 · 3/4L

Lily Davison: RSCDS XLIV 7 · Crib: MiniCribs · Diagram: Keith Rose's Diagrams

- 1-8** 1s set, cross RH, cast 2 places & dance up to face 1st corners
- 9-12** 1s set to 1st corner & change places RH with 1st corner persons who pass LSh to face 2nd corners (3L facing 2L & 2M facing 3M)
- 13-16** Original 1st corner persons set to 2nd corners & change places RH; 2nd corners pass LSh to face 1st corner positions (2L facing 1L & 3M facing 1M)
- 17-20** Original 2nd corner persons set to 1st corners (1s), change places RH & 1s end BtoB facing opposite sides as for double triangles
- 21-24** All set as in double triangles, corner persons chase 1 place clockwise **while** 1s PdB round each other to face down (Man with partner on left)
- 25-32** 1s NHJ dance down between 3s, cast up to 2nd place, dance up between 2s & cast to 2nd place

